

## Data Receive Unit with 9 Bi-directional Data Channels for a Dual Redundant Singlemode Fibre Ring - includes AMG NMS Network Management Interface

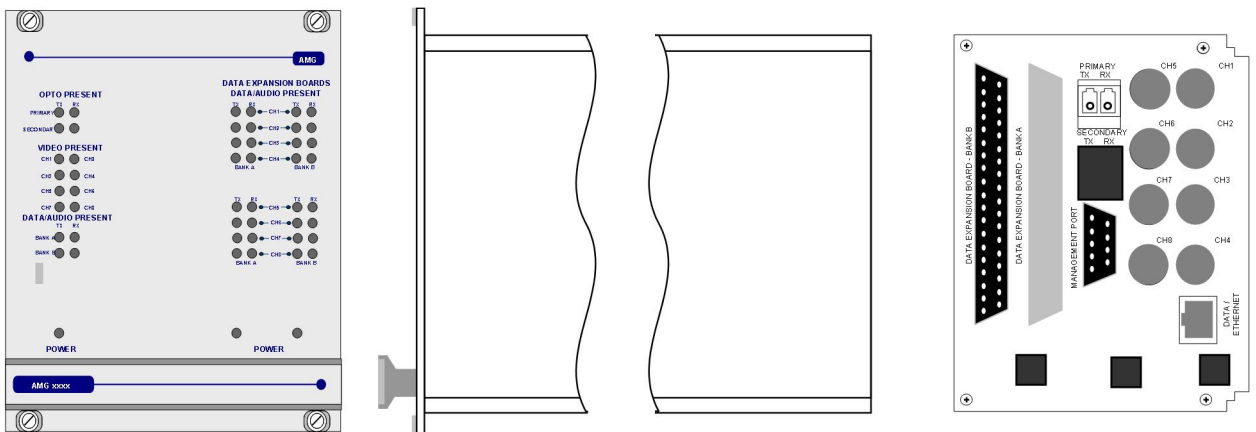

The **AMG3708BRN-DR-SF** is a rackmount data receive unit designed to receive to transmit and receive 9 bi-directional data channels to/from up to 8 **AMG3703B2-DR-SF** or **AMG3703B2R-DR-SF** rackmount equivalent insert units over a dual redundant singlemode optical fibre ring. One data channel is a multi-drop RS-485 link, the other eight data channels are effectively point to point RS-232 links.

The **AMG3708BRN-DR-SF** is designed to plug into an AMG2009 or AMG2015 subrack, which in turn fits into a 19" rack system. It also includes an AMG Management Interface to allow Management of the system using the AMG SNMP enabled Management software.

The **AMG3708BRN-DR-SF** is designed to operate with up to eight **AMG3703B2-DR-SF** data insert units. Each receiver will 'drop off' one RS-485 multi-drop channel plus up to eight RS-232 individual data channels which are being transmitted around the fibre ring.

# Contents

<b>Introduction</b>	<b>3</b>
Unit Functional Schematic.....	3
Data Channel Configuration .....	3
<b>Connections</b>	<b>5</b>
Optical Connections .....	5
Power Connection .....	5
Data and Audio Channel Connections .....	5
<b>Data and Audio Channel Configuration</b>	<b>6</b>
Data and Audio Channel Configuration.....	6
Data Channel A Configuration.....	6
Data Interface Connections Channel A .....	6
Bank B Data.....	7
Data Interface Daughter Board Options .....	7
Data and Audio Channel Configuration.....	7
Daughter Board Layout .....	7
Data and Audio Daughter Board Fitting Instruction.....	7
Data and Audio Connections Bank B.....	8
<b>Front Panel Indicators</b>	<b>9</b>
Power LED.....	9
Fibre Optic LED's .....	9
Low Speed Data LEDs .....	9
<b>Network Management</b>	<b>11</b>
NMS Operation.....	11
SNMP .....	11
Network Alarm Port .....	11
The Management Interface .....	11
Alarm Output and Reset Operation .....	13
<b>Physical Information</b>	<b>14</b>
Dimensions .....	14
Mounting Details.....	14
Removal / replacement from / to the Case.....	14
<b>Safety</b>	<b>14</b>
<b>Maintenance and Repair</b>	<b>14</b>

## Introduction

### Unit Functional Schematic

The **AMG3708BRN-DR-SF** transmits and receives optical signals from both a primary and a secondary optical channel.

The two optical channels are transmitted on the same optical fibre in opposite directions, operating at different wavelengths. The primary channel operates on 1550nm and the secondary channel on 1310nm.

The **AMG3708BRN-DR-SF** drops off up to 9 data signals transmitted from the **AMG3703B2-DR-SF** insert units. It then inserts data signals onto the outgoing optical signal.

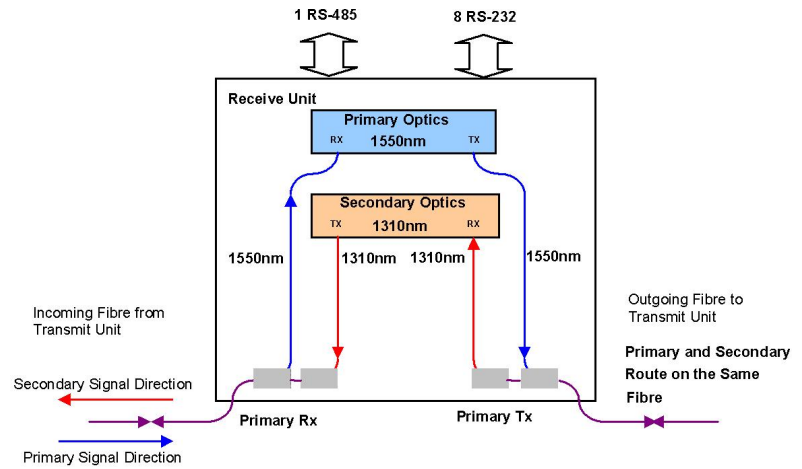

As each unit regenerates the optical signal, the optical dynamic range between each optically connected node is 17dB.

### Data Channel Configuration

At the **AMG3703B2-DR-SF** or rackmount **AMG3703B2R-DR-SF** insert unit, "B" channel data can be inserted on one to eight "B" data channels transmitted on the optical fibre. The "B" data channel number of each insert unit is set by the rotary switch on the front panel of the unit.

It is normal to set each insert unit to a different channel number. If the same number is used twice, an insert unit connected 'down stream' on the primary optical route will 'over-write' any coincident data channel coming from the previous insert unit and those data signals will be lost.

The switch channel numbers 1 to 8, correspond to data channels 1-8. Unused switch channel numbers 0 & 9 duplicate data channel selections 1 & 8 respectively. i.e. setting switch to position 0 or 1 selects data channel 1 and setting switch to position 8 or 9 selects channel 8.

The **AMG3708BN-DR-SF** or rackmount **AMG3708BRN-DR-SF** is designed to be connected in a ring or point to point system. In a ring system single channel data insert units can be combined to make an 8 channel data transmission system as illustrated below.

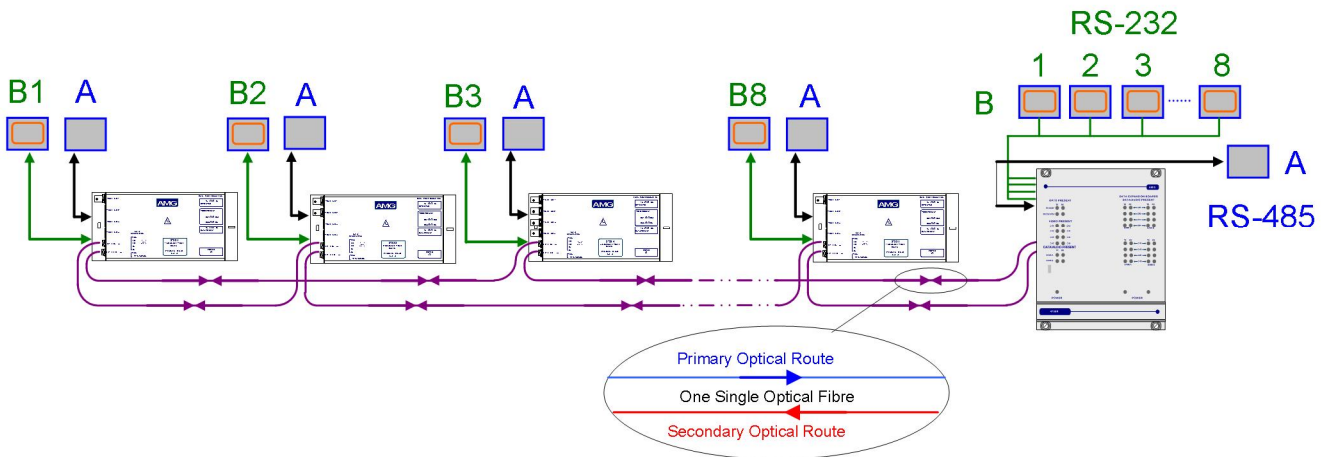

If a fibre link is broken, operation of the ring continues by making use of the secondary optical fibre route as below:

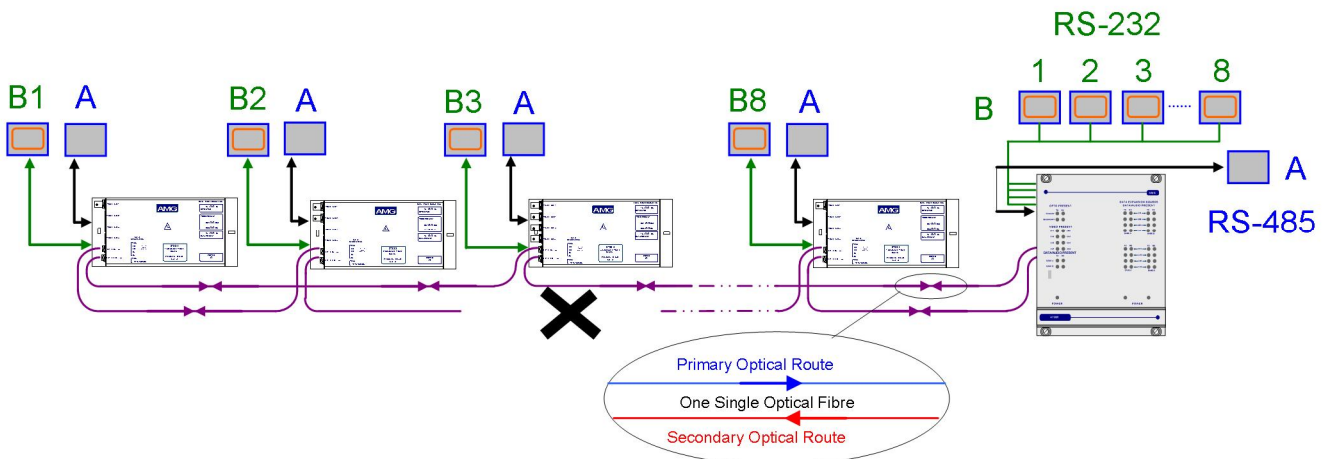

If multiple breaks occur, operation is maintained will all the units still physically connected to the receiver. For the scenario shown below data would now be lost from units 1 and 2 as there is now no physical connection between the transceivers and the receiver. However operation of units 3 and 4 to 8 remain fully functional.

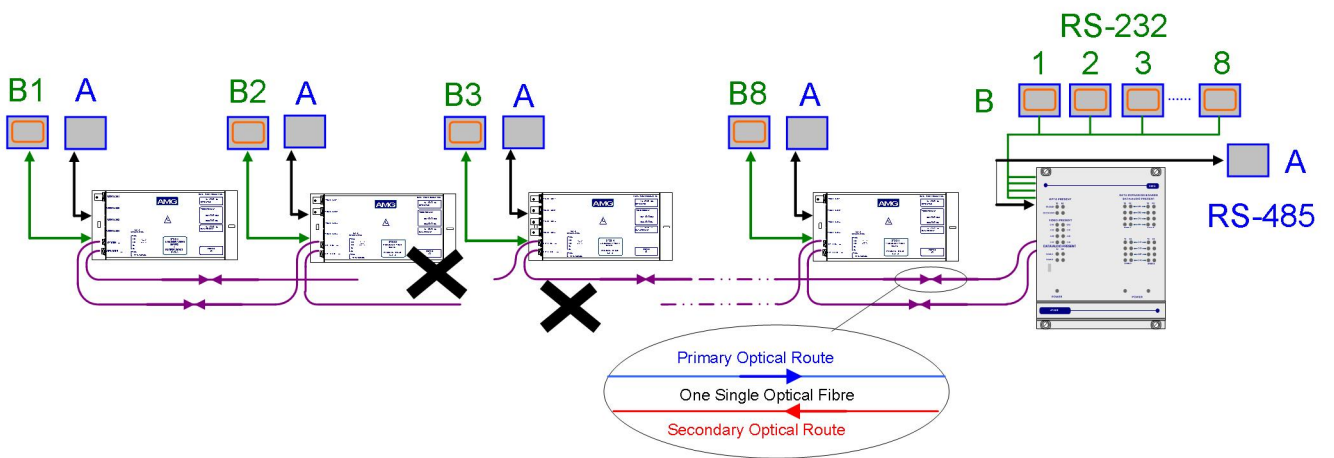

## **Connections**

---

### **Optical Connections**

#### **PRIMARY OPTO OUT**

Connector ..... LC/PC  
Primary Optical Launch Power..... -5dBm  
Wavelength..... 1550nm  
Secondary Optical Sensitivity..... -22dBm  
Wavelength..... 1310nm

#### **PRIMARY OPTO IN**

Connector ..... LC/PC  
Primary Optical Sensitivity..... -22dBm  
Wavelength..... 1550nm  
Secondary Optical Launch Power ..... -5dBm  
Wavelength..... 1310nm

### **Power Connection**

Power supply ..... from plug in connection on the AMG2009 / AMG2015 subrack  
Power consumption ..... 15 Watts max.

### **Data and Audio Channel Connections**

Total No. of Data Channels ..... 9 channels

#### **DATA CHANNEL A**

Data Channel A ..... 1 channel  
Data Connector ..... RJ45

Channel A Interface      On Board Data Interface – RS232, RS422 or RS485. Selected by slide switch above RJ45 connector.

    RS485 – switch position - high (closest to BNC connections)

    RS422 – switch position – middle

    RS232 – switch position – low (furthest from BNC connections)

#### **DATA BANK B**

Data/Audio Channels – BANK A ..... Not Used

Data/Audio Channels – BANK B ..... 8 channels

Connector ..... 37-way D-Type female connector - shielded.

Connections..... See appropriate section for connection and configuration details

For the data or audio channels to be present, appropriate data daughter boards must be fitted onto the data expansion board slots.

## Data and Audio Channel Configuration

### Data and Audio Channel Configuration

The **AMG3708BN-DR-SF** and rackmount equivalent **AMG3708BRN-DR-SF** sends and receives data to/from Channel A and Bank B. Channel A is a single data interface selectable by the user with the slide switch on the rear panel. Bank B carries up to 8 channels of data / audio, the physical interface of which is determined by fitment of AMG data or audio daughter boards onto the B Channel data expansion board slots.

### Data Channel A Configuration

Channel A is always present and allows for a RS232, RS422 (full duplex, four wire) or RS485 (half duplex, two wire) interface depending on the position of the switch located above the RJ45 connector. The switch signifies the presence of the X16004 Low Speed Data/Audio Interface Board. If there are LED's present on the RJ45 connector then an X16003 Ethernet Interface Board is fitted.

The data input for both the RS485 and the RS422 modes detects a tri-state input condition by monitoring the differential voltage level across the input. A differential level below 600mV positive or negative will be detected as a tri-state condition. A level above 600mV positive or negative will be detected as a logic 1 or logic zero respectively. It is important therefore to terminate the RS485 bus or the RS422 input bus using 120Ω if a pre-bias is present on the RS485 or RS422 bus.

A large number of third party equipment manufacturers apply a pre-bias on their RS485 bus. This pre-bias is applied by pulling one arm of the RS485 bus high (+5 volts) and the other arm low (0 volts) using high value resistors within the third party equipment. In order to ensure that the AMG equipment detects a tri-state condition, then these resistors should have a value above 5kΩ. If the third party bias resistors are less than the 750Ω the bus can be double or triple terminated as required to ensure that a tri-state level is detected.

Note: The Data Channel A is shipped from the factory set up for RS485 operation unless otherwise requested.

### Data Interface Connections Channel A

RJ45 Pin No.	Channel A			Cat 5/6 Cable Colour Code T568B
	RS485 [switch high]	RS422 [switch mid]	RS232 [switch low]	
1		IN + (A)	GND	White/orange
2		IN - (B)	IN	Orange
3				White/green
4				Blue
5				White/blue
6				Green
7	IN/OUT + (A)	OUT + (A)	N/A	White/brown
8	IN/OUT - (B)	OUT - (B)	OUT	Brown

Note: (A) or (B) in brackets in above table refers to RS485 / RS422 data specification, not Channel A, Channel B.

### **Bank B Data**

Data Bank B channels are operational when fitted with appropriate daughter boards.

### **Data Interface Daughter Board Options**

The data interface daughter board options are as follows:

Option Code 'x'	Part No.	Description
0	X12542	4 Wire Audio Interface Daughter Board
1	X04057	RS422/485 Data Interface Daughter Board
2	X04049	RS232 Data Interface Daughter Board
3	X04058	20mA Current Loop Data Interface Daughter Board
4	X12579	TTL Data Interface Daughter Board
5	X12578	Contact Closure Data Interface Daughter Board
6	X13038	FTT10A Echelon Lonworks Data Interface Daughter Board

### **Data and Audio Channel Configuration**

The data expansion board slots are accessed by removing the AMG unit from its case. A data channel is active when a daughter board is installed in the required data channel slot. Each data interface board enables one bi-directional channel.

### **Daughter Board Layout**

The channel slots are as follows:

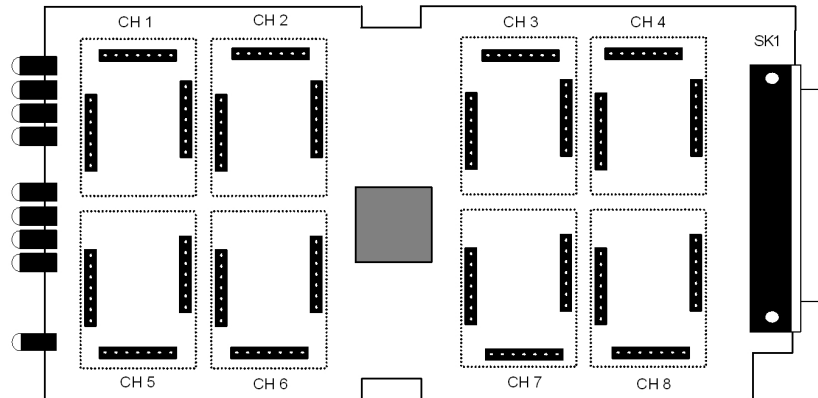

### **Data and Audio Daughter Board Fitting Instruction**

The data and audio daughter boards pushed on to the pin headers mounted on the data expansion boards. Ensure that the connectors are lined up correctly and not offset before pushing firmly in place. Note that the data and audio channel numbers are associated with each slot. This allocates the pin numbers on the rear panel connector together with the front panel LED indicators.

## Data and Audio Connections Bank B

The BANK B data/audio channels pin connections on the rear panel connectors are as follows:

Pin No.	Description	Bank
1	Audio/Data CH1 IN + (A)	B
2	Audio/Data CH1 IN - (B)	B
3	Audio/Data CH2 IN + (A)	B
4	Audio/Data CH2 IN - (B)	B
5	Audio/Data CH3 IN + (A)	B
6	Audio/Data CH3 IN - (B)	B
7	Audio/Data CH4 IN + (A)	B
8	Audio/Data CH4 IN - (B)	B
9	GND	B
10	GND	B
11	GND	B
12	Audio/Data CH5 IN + (A)	B
13	Audio/Data CH5 IN - (B)	B
14	Audio/Data CH6 IN + (A)	B
15	Audio/Data CH6 IN - (B)	B
16	Audio/Data CH7 IN + (A)	B
17	Audio/Data CH7 IN - (B)	B
18	Audio/Data CH8 IN + (A)	B
19	Audio/Data CH8 IN - (B)	B

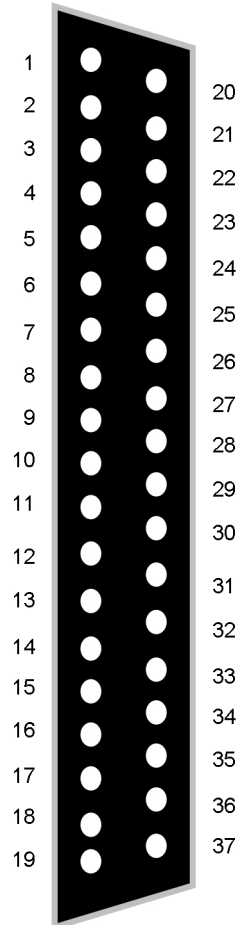

Pin No.	Description	Bank
20	Audio/Data CH1 OUT + (A)	B
21	Audio/Data CH1 OUT - (B)	B
22	Audio/Data CH2 OUT + (A)	B
23	Audio/Data CH2 OUT - (B)	B
24	Audio/Data CH3 OUT + (A)	B
25	Audio/Data CH3 OUT - (B)	B
26	Audio/Data CH4 OUT + (A)	B
27	Audio/Data CH4 OUT - (B)	B
28	GND	B
29	GND	B
30	Audio/Data CH5 OUT + (A)	B
31	Audio/Data CH5 OUT - (B)	B
32	Audio/Data CH6 OUT + (A)	B
33	Audio/Data CH6 OUT - (B)	B
34	Audio/Data CH7 OUT + (A)	B
35	Audio/Data CH7 OUT - (B)	B
36	Audio/Data CH8 OUT + (A)	B
37	Audio/Data CH8 OUT - (B)	B

Note: (A) or (B) in brackets in above table refers to RS485/RS422 data specification not Bank A, B.

See Data or Audio Daughter Board Instruction Sheet for meaning of Audio/Data IN+, Audio/Data IN-, Audio/Data OUT+, and Audio/Data OUT- for each data type.



## Front Panel Indicators

---

### Power LED

Power .....	Green	-	unit powered
	Off	-	no power applied to unit

### Fibre Optic LED's

Primary Opto Sync TX.....	Green	-	optical channel transmitting
	Off	-	optical channel not transmitting
Primary Opto Sync RX .....	Green	-	optical channel receiving
	Org	-	optical channel receiving but not sync.
	Off	-	optical channel not receiving
Secondary Opto Sync TX.....	Green	-	optical channel transmitting
	Off	-	optical channel not transmitting
Secondary Opto Sync RX .....	Green	-	optical channel receiving
	Org	-	optical channel receiving but not sync.
	Off	-	optical channel not receiving

### Low Speed Data LEDs

#### Channel A

Data Present TX (RS485 or RS422) ...	Green	-	logic zero (+V, -V) present on IN+, IN-
	Red	-	logic one (-V, +V) present on IN+, IN-
	Off	-	tri-state off or no connection on IN+, IN-
Data Present TX (RS232) .....	Green	-	logic zero (+V) present on input IN+
	Red	-	logic transitions present on input IN+
	Off	-	logic one (-V) present on input IN+

This represents the data signals being transmitted on the optical fibre

Data Present RX (RS485 or RS422)...	Green	-	logic zero (+V,-V) present on OUT+, OUT-
	Red	-	logic one (-V,+V) present on OUT+, OUT-
	Off	-	tri-state off or no connection on OUT+, OUT-
Data Present RX (RS232) .....	Green	-	logic zero (+V) present on OUT+
	Red	-	logic transitions present on OUT+
	Off	-	logic one (-V) present on OUT+

This represents the data signals being received on the optical fibre

#### BANK B (When RS232 data daughter board fitted)

Data Present CH1-8 TX .....	Green	-	logic zero (+V) present on IN+
	Red	-	logic transitions present on IN+
	Off	-	logic one (-V) present on IN+

This represents the data signals being transmitted on the optical fibre

Data Present CH1-8 RX.....	Green	-	logic zero (+V) present on OUT+
	Red	-	logic transitions present on OUT+
	Off	-	logic one (-V) present on OUT+

This represents the data signals being received on the optical fibre

**BANK B** (When RS485 / RS422 data daughter board fitted)

Data Present CH1-8 TX.....	Green	-	logic zero (+V, -V) present on IN+, IN-
	Red	-	logic transitions present on IN+, IN-
	Off	-	logic one (-V, +V) present on IN+, IN-

This represents the data signals being transmitted on the optical fibre

Data Present CH1-8 RX .....	Green	-	logic zero (+V, -V) present on OUT+, OUT-
	Red	-	logic transitions present on OUT+, OUT-
	Off	-	logic one (-V, +V) present on OUT+, OUT-

This represents the data signals being received on the optical fibre

**BANK B** (When audio daughter board fitted)

Audio Present CH1-8 TX .....	Green	-	audio present > -40dBm
	Red	-	audio present > 0dBm (overload at +6dBm)
	Off	-	audio not present or < -40dBm

This represents the audio signals being transmitted on the optical fibre

Audio Present CH1-8 RX.....	Green	-	audio present > -40dBm
	Red	-	audio present > 0dBm (overload at +6dBm)
	Off	-	audio not present or < -40dBm

This represents the audio signals being received from the optical fibre.

## **Network Management**

---

Network Management of the system is provided by the AMG Management Interface which allows Management using the AMG SNMP enabled Management software.

### **NMS Operation**

Requires Network Management "N" option in each Rx (Receive) or Tx (Transmit) unit.  
Recommended for Dual Redundant Options to give knowledge of failure  
Rx collects information regarding all attached Tx units

### **Interface**

- 9 Way D-type management port on each Rx or Tx
- RS-232 or RS-485 on Management Port
- Multiple Rx/Tx units use RS-485 and effectively parallel all the RS-485 ports together
- Connect to PC RS-232 Port via RS-485/RS-232 convertor

### **Proprietary GUI**

- Loss of unit
- Loss of Optical Input
- Loss of Video Input

### **SNMP**

SMNP Compatibility: SMNP Version 1  
AMG3700 Device do NOT act as SNMP Agents

PC running AMG NMS software is the only 'true' SNMP Agent

- Provides Proxy access to all AMG devices
- SNMP Community String used to differentiate between AMG devices

### **Network Alarm Port**

Alarm Output: Normally Closed

Opens when loss of :

- Video at any insert node
- Primary optical input at any node
- Secondary optical input at any node
- Any node through a power down
- Power at the receiver

Closed by: Reset

### **The Management Interface**

The Management Interface is fitted to AMG receivers / transmitters and is signified by a 'N' in the part number

Each management interface, thus each receiver or transmitter, has an ID number with is identified below the management port. This ID number is used by the AMG Network Management System (NMS) to identify the unit.

The physical interface is a 9 way female D-type connector. It supports either RS-232 or RS-485.

**Management Port Pin-out:**

Pin Number	RS-232 Connection	RS-485 Connection
1	-	Data B (+)
2	RD (data out of port)	Data A (-)
3	TD (data into port)	-
4	Connect to DTR held -ve or shorted to ground	-
5	SG (signal ground)	SG (signal Ground)
6	Alarm Output	Alarm Output
7	Alarm Output	Alarm Output
8	Alarm reset (Gnd)	Alarm reset (Gnd)
9	Alarm reset	Alarm reset

For multiple Management Ports it is recommended that the RS-485 interface is used with each RS-485 pair connected in parallel. In this case an RS-485 to RS-232 / USB converter is required in order to connect to a standard PC Comms. Port.

The time delay between receiving a data request and sending out a response from the port is 625µs. Therefore any RS-485 converter should have a 'turn around' time or 'transmit dwell' time equal to or less than 625µs.

**Recommended RS-485 Converter's are:**

RS-485 to RS-232

Dataforth DCP485-S: Available in the UK from <http://uk.farnell.com/> Order No. 300-9348

**Settings on the DCP485-S:**

- RS-485 Switch Settings: 1-UP, 2-DOWN, 3-DOWN, 4-UP, 5-DOWN, 6-DOWN, 7-DOWN, 8-UP
- RS-232 Switch Settings: 1-DOWN, 2-UP, 3-DOWN, 4-UP
- DCE/DTE set to DCE.

RS-485 to USB

B&B 485USBTB-2W: Available in Europe from <http://www.bb-europe.com/> Order No. 485USBTB-2W

**Connections to management port:**

Management Port	DCP485-S	485USBTB-2W
1	2 or 4	B+
2	3 or 5	A-
5	GND	GND

**NOTES:**

On the DCP485-S, pins 3 and 5 are connected together and pins 2 and 4 are connected together. On the 485USBTB-2W, there are 2 pairs of terminals both labeled A-, B+, either pair may be used.

### ***Alarm Output and Reset Operation***

The alarm output and reset is designed to indicate a change of state of the fibre loop or spur attached to the receiver. The Alarm output is a volts free contact relay output (rating: 0.5A at 125VAC or 1A at 24VDC). It normally open, which means that when not powered the contacts will be open circuit.

On power up the contacts will close and will remain closed for up to 5 seconds. During this time the receiver will monitor and record the state of the AMG transmit units connected to the receiver.

The contacts will then remain closed until there is a change from this recorded state. A change of state would be:

- Addition or loss of video at any insert node
- Addition or loss of primary optical input at any node
- Addition or loss of secondary optical input at any node
- Power up or down of any node
- Loss of power at the receiver

Following a change of state the contacts will remain open, regardless of whether the alarm condition reverts back to its previous state, until the a reset signal is presented to the alarm input connections. The alarm reset input is biased at 5V via a 1k $\Omega$  resistor. To reset the alarm, the alarm reset is required to be pulled to ground, either by a volt-free contact or an open collector output. The alarm output will be held in a closed state whilst the alarm reset is connected to ground.

On release of the alarm reset, the alarm output will remain in a closed state until the next change of state to the AMG transmit unit connected to the receiver. The alarm output may not register a change of state which happens within 5 seconds of release of the alarm reset.

## **Physical Information**

---

### **Dimensions**

Height.....3U Plug-in  
Width.....21HP  
Depth .....170mm excluding connectors  
Weight.....1200grams

### **Mounting Details**

The unit is designed to be mounted within an AMG2009 or AMG2015 Subrack on standard card guides.

### **Removal / replacement from / to the Case**

Note: - The AMG unit PCB's are static sensitive. Handle with proper care and use normal electrostatic discharge (ESD) procedures. Use properly grounded protection (for example, wrist straps) when handling the PCB.

To remove units from the case to access the data expansion boards and the daughter boards, remove the 2 or 4 fixing screws on the rear panel and slide the PCB's out of the case. Ensure that the fibres do not snag or get trapped.

To replace the PCB's into the case, slide the PCB's gently into the case aligning the boards with the appropriate slots. Ensure that the fibre do not snag or get trapped.

## **Safety**

---

AMG Optical Fibre Products use Class 1 laser systems in accordance with EN 60825-2:2000.

It is always advisable to follow good practice when working with optical fibre systems. This includes:

- Do not stare with unprotected eyes or with any unapproved collimating device at fibre ends or connector faces, or point them at other people.
- Use only approved filtered or attenuating viewing aids

For other safety issues and advice on good practice associated with optical fibre systems, please see EN 60825-2:2000 or your local safety officer.

## **Maintenance and Repair**

---

There are no user serviceable parts within AMG products. See unit data sheet for full specification.

In case of problem or failure, please call your local support centre or contact: **AMG Systems Ltd.** at 3 The Omega Centre, Stratton Business Park, Biggleswade, Beds., SG18 8QB, UK.

Phone	+44 (0) 1767 600 777
Technical Support	+44 (0) 1767 604 491
Email	techsupport@amgsystems.com

This page is intentionally blank.

This page is intentionally blank.